

Beispiel - Kombinationen

Example - combinations

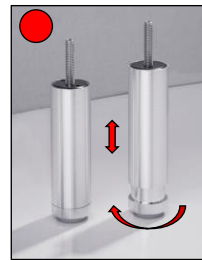
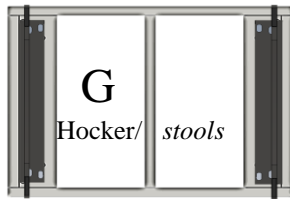
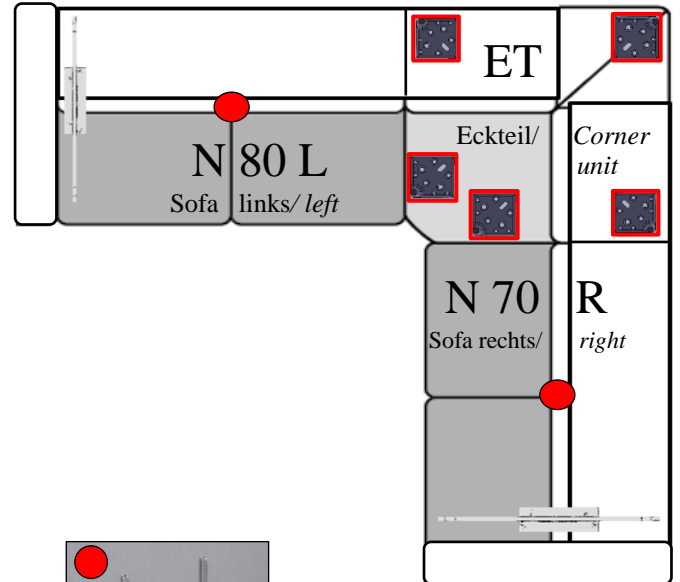
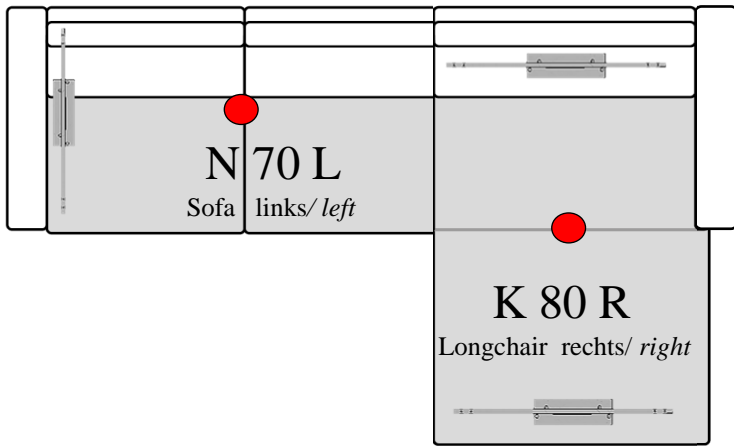

Höhenverstellbarer Stützfuß

Height adjustable support leg

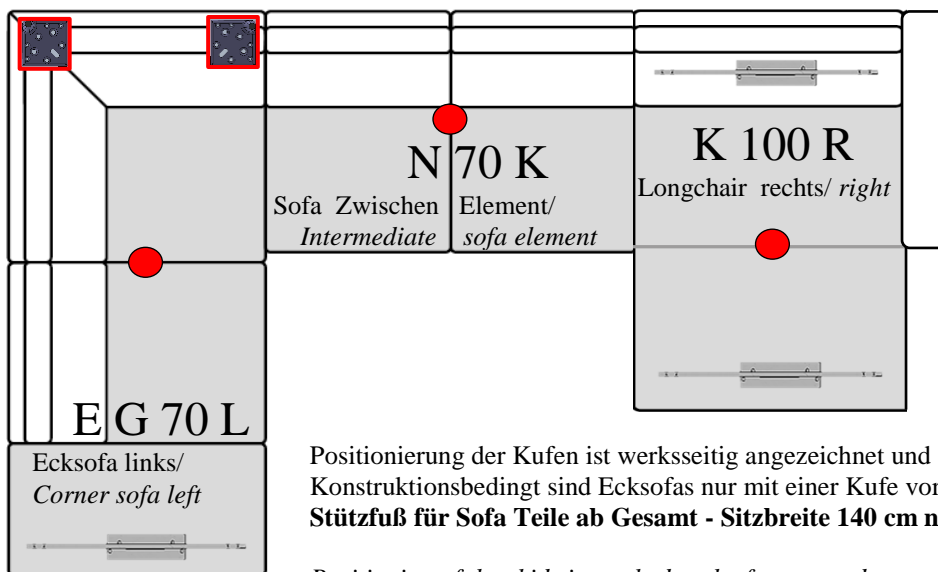

Positionierung der Kufen ist werksseitig angezeichnet und mit Montagegleitern vorgegeben. Konstruktionsbedingt sind Ecksofas nur mit einer Kufe vorne möglich.
Stützfuß für Sofa Teile ab Gesamt - Sitzbreite 140 cm notwendig!

*Positioning of the skids is marked at the factory and pre-set with assembly glides. For design reasons, corner sofas are only possible with one skid at the front.
Support leg for sofa parts from total - seat width 140 cm necessary!*

Montagezubehör

Assembly accessories



Sofa Kufen
Sofa skids



Kufe F T9, Bauhöhe 17 cm
Skid F T9, total height 17cm

Kufe F 08, Bauhöhe 19 cm
Skid F 08, total height 19 cm



S3

M8 x 35 mm



U1

20 x 8 x 1,5 mm



Hocker Kufen
Stool skids



Kufe F T9, Bauhöhe 17 cm
Skid F T9, total height 17cm

Kufe F 08, Bauhöhe 19 cm
Skid F 08, total height 19 cm



S3

M8 x 35 mm



U1

20 x 8 x 1,5 mm

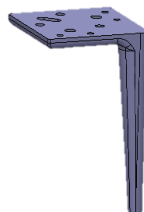
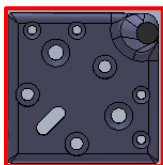

Fuß F S1/ F V8
Leg F S1/ F V8



S1

5 x 25 mm



S2

M8 x 35 mm

Beispiel Kufenmontage bei Ecksofas

Example skid assembly for corner sofas

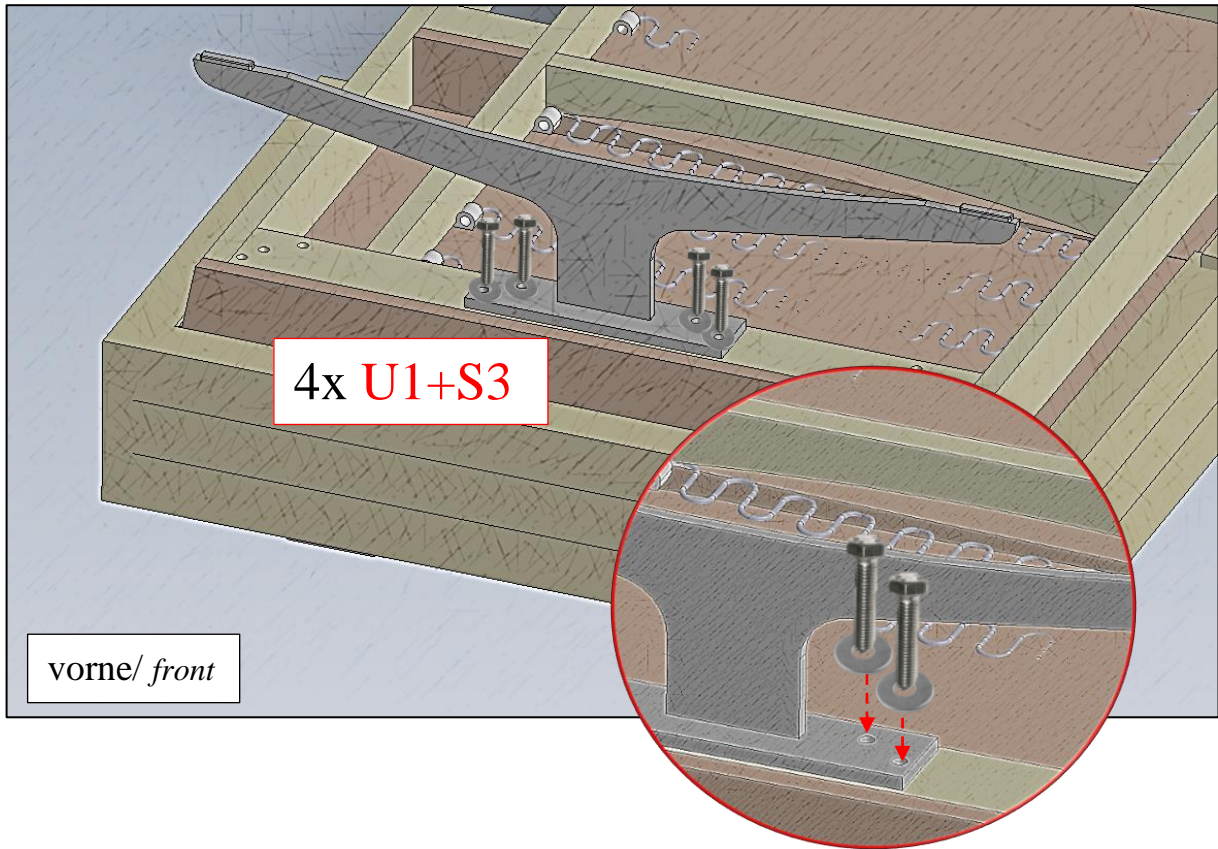

Beispiel Fußmontage bei Ecksofas

Example skid assembly for corner sofas

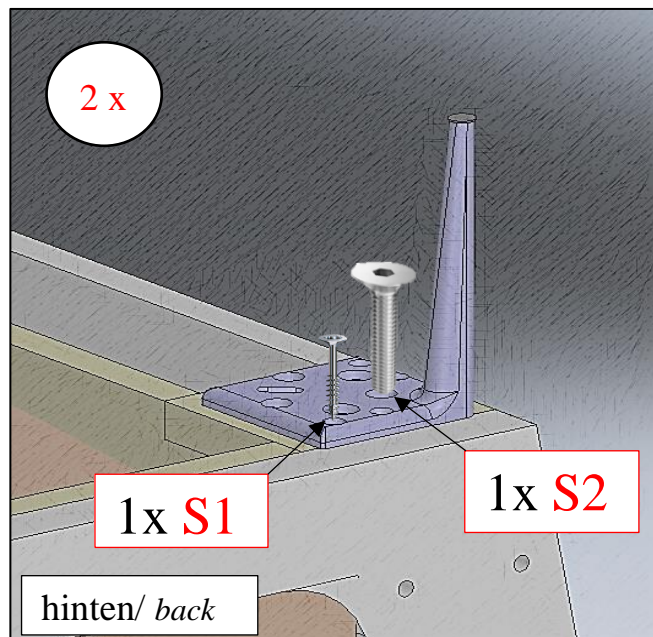

Beispiel Kufenmontage bei allen Longchairs und Sofas

Example skid assembly for all long chairs and sofas

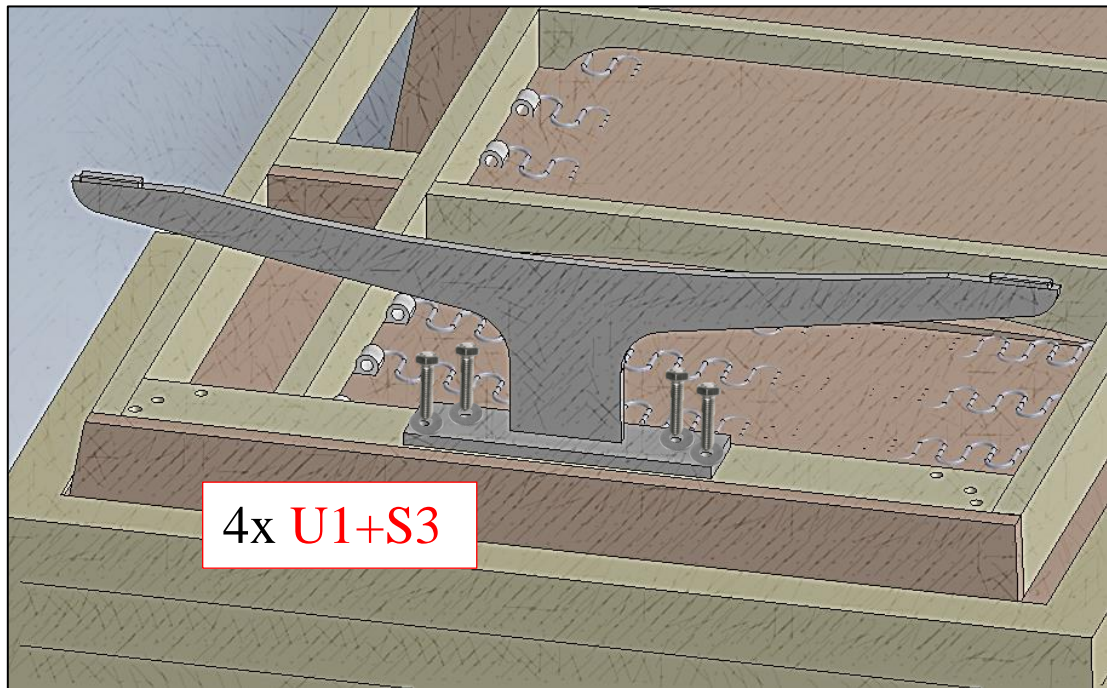

Beispiel Kufenmontage bei Hockern

Example skid assembly for stools

